

Combination of Ground Improvement Techniques For Support of Shallow Foundations in Karst

Timothy C. Siegel P.E., Member, Geo-Institute¹
J. Matthew Caskey, P.E., Member, Geo-Institute²
Dennis A. Huckaba, P.E., Member, Geo-Institute³

Abstract

The subsurface conditions for a proposed six-story \$94M medical facility in Knoxville, Tennessee, consisted of a thick clay layer overlying an irregular weathered limestone bedrock surface. Because the design loads were significant and because of the sinkhole risk associated with the underlying limestone bedrock, the initial design considered the use of drilled shafts bearing on rock. While drilled shafts represented a robust technical solution, construction of drilled shafts in karst can be expensive and time-consuming. In an effort to save both time and money, the authors and other members of the project design team developed a combination ground improvement program to allow support of the medical facility on conventional shallow foundations. The combination ground improvement program consisted of (1) cap grouting the rock surface to significantly reduce the sinkhole risk, and (2) construction of *Geopier*[®] elements to reinforce and stiffen the soils immediately below the planned shallow foundations. For development and refinement of the combination ground improvement program, extensive subsurface characterization was performed using cone penetration testing (CPT) at every column location. The CPT results were used to develop three dimensional models of the subsurface conditions including pertinent karst features. The cost savings provided by the combination ground improvement program is estimated to be in excess of \$1M.

¹ Chief Engineer, S&ME, Inc., Louisville, Tennessee.

² Principal, *Geopier*[®] Foundation Company – MidSouth, LLC, Lakeland, Tennessee.

³ Geotechnical Department Manager, S&ME, Inc., Louisville, Tennessee.

Introduction

Rock-bearing drilled shafts have historically been the foundation of choice for major buildings and other structures constructed in the limestone and dolostone geology of East Tennessee. In the region, drilled shafts are typically advanced to the top of rock with a soil auger and fully cased. Rock augers, core barrels, and other tools are used to advance the shaft excavation into rock. Until very recently, the accepted engineering observation practice has been to lower an engineer into the excavation to observe the prepared rock surface prior to placement of the reinforcing steel and concrete. Due to safety concerns, alternative methods, such as downhole video, have been employed to confirm the rock subgrade conditions. Albeit expensive, drilled shafts represent a robust foundation choice for overcoming challenging karst conditions.

Given their acceptance in the construction community, drilled shafts were initially selected as the foundations for a new six-story, \$94M medical center at the Fort Sanders Parkwest Hospital in Knoxville, Tennessee. During project budgeting, Geopier[®] Foundation Company alternatively proposed to improve the upper subgrade, increase bearing capacity and decrease settlement of shallow foundations by installing *Rammed Aggregate Piers*[™]. Where drilled shafts essentially eliminated the sinkhole risk to the project, it was recognized that ground improvement using solely Geopier[®] soil reinforcement would not decrease the sinkhole risk. In fact, it was foreseeable that the construction of aggregate piers in certain conditions could increase the sinkhole risk. To address the sinkhole conditions, a cap grouting pre-treatment program was combined with rammed aggregate piers for support of shallow foundations.

Sinkhole and Karst Hazards

The karst-related hazards of Valley and Ridge physiographic province are well-established in technical literature (Siegel and Belgeri, 1995; Sowers, 1996). The risk (i.e., risk = hazard + consequences) to the performance of structures is mostly associated with activation of relic sinkhole features. In other words, construction-related impacts to the subsurface conditions exacerbate the downward migration (and resulting softening) of overburden soils into the existing rock openings. Other karst features, such as collapse of rock caves and solutioning of the parent rock within the design life of the structure are generally extremely rare. As is described more thoroughly in subsequent portions of this paper, the characteristic profile at this site consisted of a thick layer of residuum overlying relatively continuous karst bedrock. Considering the range of potential karst conditions, the deeper soil exhibited lesser softened conditions than the authors have observed at most other East Tennessee projects.

Site Characterization

The site characterization for the ground improvement design consisted of cone penetration testing (CPT) at every column location and along continuous foundations with some exceptions where access was very limited (S&ME, Inc., 2003). On the basis

of approximately 100 CPT soundings, the subsurface was characterized as a thick layer of stiff residuum overlying an irregular bedrock surface. Figure 1 shows a three-dimensional rendering of the limestone bedrock surface developed from the CPT data.

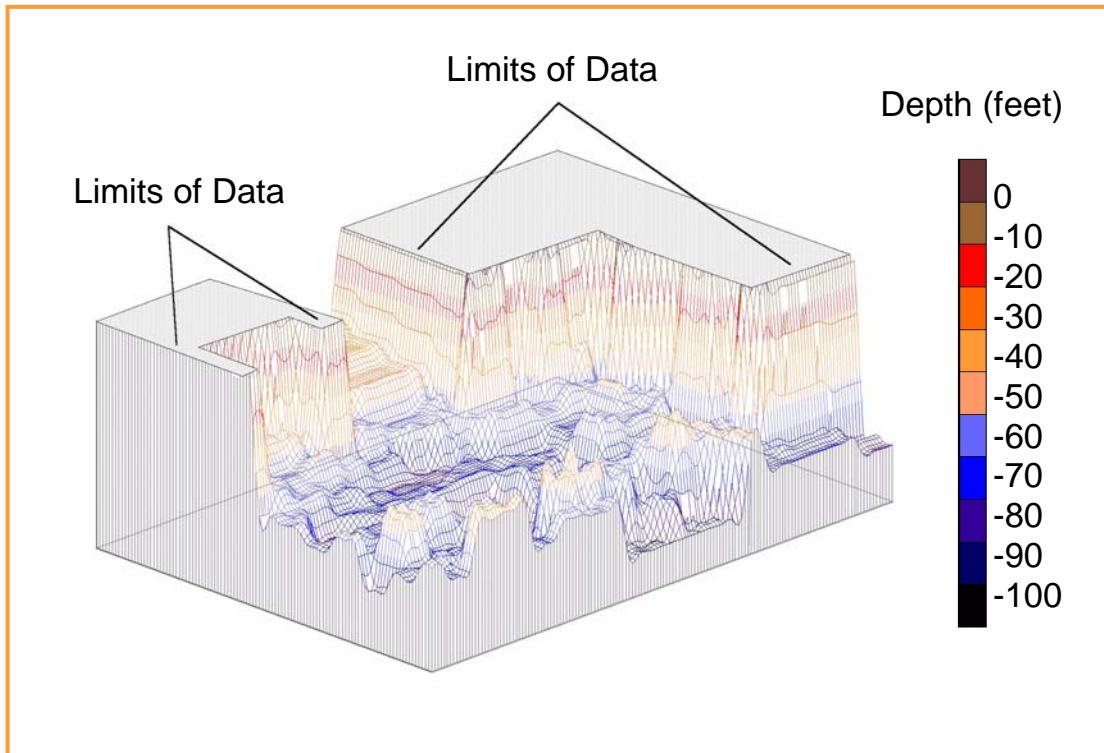

Figure 1. Interpreted Bedrock Surface Developed From CPT Data (1 ft = 0.305m)

Generally, the residuum ranged from approximately 18 to 24 meters (60 to 80 feet) in thickness with a corrected tip resistance ranging from 2 to 4 MPa (20 to 40 tsf) in the stiffer portions. At some locations, the corrected tip resistance reduced to near zero which was interpreted by the authors to be evidence of karst solutioning and associated downward migration of overburden soil. It is the zones of very low corrected tip resistance that were targeted by the cap grouting program. Interpretation of the CPT data is that soft, low consistency soil zones, where present, were directly above the rock surface and 1.5 to 3 meters (5 to 10 feet) in thickness.

Ground Improvement Approach

The ground improvement design consisted of a combination of (1) cap grouting and (2) rammed aggregate piers. Cap grouting is the injection of low mobility grout to fill voids and to form a barrier at the top of the porous karst bedrock (Siegel et al., 1999). The purpose of the cap grouting was to reduce the potential for soils and pier aggregate to ravel downward into rock openings that could compromise the integrity of the shallow foundation subgrades. An idealized profile of a cap grouting is shown in Figure 2. For this project, the authors identified initial target areas to receive cap

grouting based on extensive cone penetration testing and the application of engineering judgment. During field activities for the cap grouting, the program was continuously modified, based on the behavior of the drilling, grouting equipment and other available data to insure that engineering goals were achieved. Approximately 1340 lineal meters (4400 lineal feet) of temporary casing were installed to place approximately 500 cubic meters (650 cubic yards) of low mobility grout.

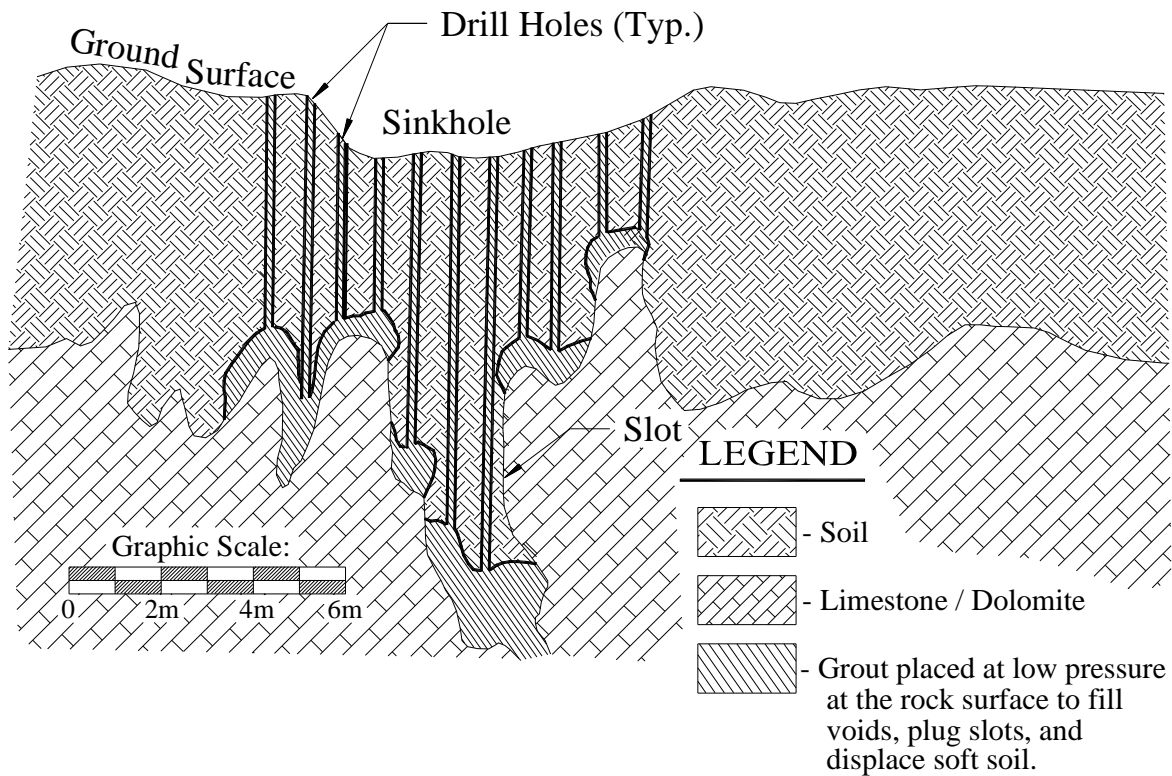

Figure 2. Idealized Profile of Cap Grouting

Rammed aggregate piers or Geopier elements are installed via the three-step process shown in Figure 3. The aggregate piers are installed by first drilling a 0.6- to 0.75-meter (24- to 30-inch) diameter hole to depths ranging from 2.1- to 9.1 meters (7 to 25 feet) below planned footing bottom elevations. Well-graded, highway base-course stone is then introduced into the drilled cavity in approximate 0.3-meter (12-inch) lifts. Each lift of aggregate is compacted, or tamped in place for approximately 10 to 20 seconds using a down-hole impact hammer equipped with a specially designed beveled foot. During the ramming process, the beveled shape of the tamper foot forces the stone downward, but also laterally into the sidewall of the drilled cavity, thus increasing the lateral stress in the matrix soil. This increase in lateral stress provides additional stiffening and increased normal stress perpendicular to the perimeter shearing surface. (Lawton et al., 1994; Wissmann and Fox, 2000)

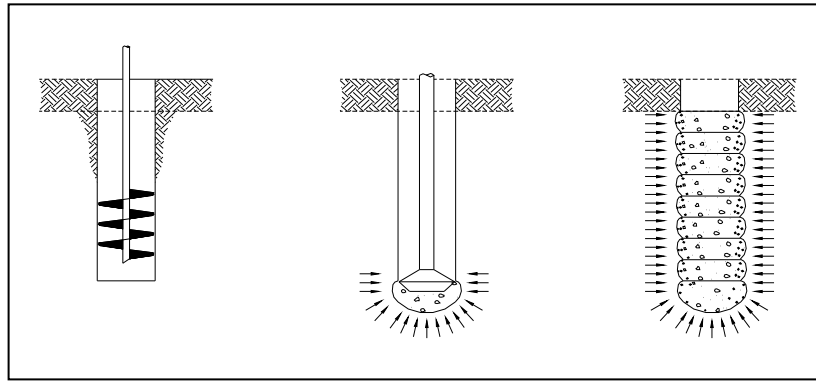

Figure 3. Three-Step Geopier Construction Process

The installation process of rammed aggregate piers also results in the development of high internal angles of friction (White et al. 2002; Fox and Cowell, 1998), increases the composite shear strength beneath the foundation, and allows for the use of relatively high bearing pressures in soils that, otherwise unreinforced, would yield much lower design bearing pressures. The result is a reinforced soil mass that exhibits an overall high allowable bearing pressure and lower compressibility.

When necessary to resist uplift loads on spread foundations, Geopier elements are equipped with uplift harnesses. The harness consists of a flat steel plate connected to threaded rods (Figure 4). The assemblage is installed at the bottom of the pier, just above the bottom bulb. The rods extend upward from the bottom of the pier along the shaft sidewall. After the anchor assemblage has been placed at the bottom of the pier, the pier is constructed as described previously. At the top of the pier, the threaded rods are connected to pullout plates or elbows that form structural connections to the concrete footing. During uplift loadings, the threaded rods transfer the footing uplift loads to the bottom plate. Shearing along the cylindrical surface or the rammed aggregate pier resists the upward movement of the bottom plate (Caskey, 2001). Thus, the rammed aggregate pier soil reinforcing system serves to resist both axial and tensile foundation loading conditions. Figure 5 shows a footing excavation where uplift anchors were required.

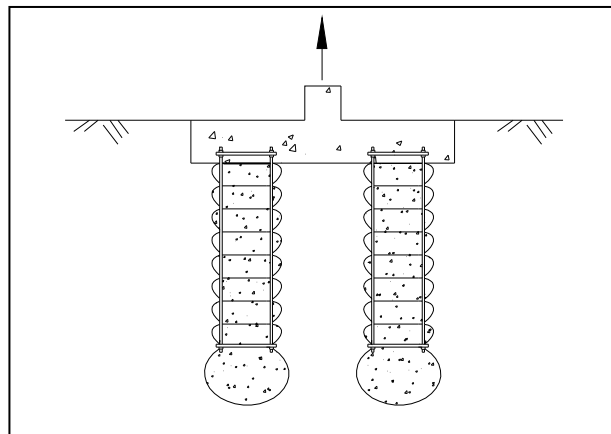

Figure 4. Geopier Elements with Uplift Harnesses



Figure 5. Uplift Anchor Rods in Subgrade

For this project, the design allowable bearing pressure was 335 kPa (7000 psf). Calculated settlements for the Geopier-supported foundations were less than the project criterion of 25 mm (1 inch) total and 13 mm (½ inches) differential. Just over 2000 Geopier elements were installed under all column and wall footings, as well as large area mat foundations supporting elevators and stairwells. Figure 6 shows a photograph of Geopier installations at the project site.



Figure 6. Geopier Construction at Project Site

Advantages and Disadvantages

As with most engineering undertakings, there are both advantages and disadvantages to the cap grouting/rammed aggregate pier ground improvement approach in karst. From a construction perspective, this ground improvement does not require deep soil and rock excavation as do the typical alternatives. Neither does it require particularly “good” rock conditions immediately at the foundation location. In contrast, the flexible cap grouting program is targeted at poorer soil conditions and where the foundation requirements are most critical. The Geopier elements are then constructed as required for foundation bearing capacity, settlement, and uplift resistance. The only significant adjustment made for karst conditions is that a well-graded crushed stone was used in rammed aggregate pier installations. From a cost perspective, the ground improvement approach avoids the risk of poor rock bearing conditions leading to extra rock excavation.

The cap grouting/Geopier ground improvement approach does rely, in part, on support from the overburden soil. Thus, such projects will be exposed to some continued sinkhole risk over their design life. This performance risk will depend on karst features underlying the site, the effectiveness of cap grouting program, and the project specifics.

Concluding Remarks

As discussed in this paper, a combination of these two techniques, cap grouting and Geopier rammed aggregate piers, was constructed as an alternative to rock-bearing drilled shaft foundations in karst terrain. Although these ground improvement techniques are established, we believe that this project may be the first application of a combination of cap grouting and Geopier elements in such a manner. Furthermore, besides this original application of existing technology, extensive cone penetration was used to develop three-dimensional models for planning and executing the cap grouting program. This represents a significant innovative advancement to standard auger-type drilling and standard penetration testing for the characterization of karst subsurface conditions. In addition to the extensive preliminary modeling, a settlement monitoring program was undertaken during construction of the building, to observe settlements at pre-selected column locations. As of the writing of this paper, the structure has been topped-out, and maximum reported settlements are less than 13 mm (½ inches).

The project presents a prototype alternative to the two foundation types that are most common in larger buildings in karst: drilled shafts and micropiles. Our design for combination cap grouting/rammed aggregate pier subgrade improvement may be considered most applicable where the stiff soil overburden is relatively thick and the karst bedrock solutioning (or weathering) is not extensive. The authors recognize that drilled shafts and micropiles may be suitable for a wider range of karst profile conditions. However, the robustness provided by rock-bearing drilled shafts or micropiles comes at a significantly greater cost, especially where rock is deep.

Acknowledgements

The authors gratefully acknowledge Mr. Danny Edsell and Mr. Darrell Calloway who represent client Covenant Health Properties. We also thank S&ME, Inc. and Geopier Foundation – MidSouth LLC for support in the preparation of this paper.

References

- Caskey, J.M. (2001). "Uplift Capacity of Rammed Aggregate Pier™ Soil Reinforcing Elements," *Masters Thesis*, University of Memphis, Memphis, TN
- Fox, N. S. and Cowell, M.J. (1998). *Geopier foundation and soil reinforcement manual*. Geopier Foundation Company, Inc., Scottsdale, AZ.
- Lawton, E.C., Fox, N.S., and Handy, R.L. (1994) "Control of Settlement and Uplift of Structures Using Short Aggregate Piers," *Proceedings*, IN-SIU Deep Soil Improvements, Atlanta, GA.
- S&ME, Inc. (2003). *Report of Cone Penetration Testing and Preliminary Cap Grouting Program, Fort Sanders Parkwest MOB*, Project No. 1431-02-563.
- Siegel, T.C. and Belgeri, J.J. (1995) "The Importance of a Model in Foundation Design over Deeply-Weathered, Pinnacled, Carbonate Bedrock," *Proceedings*, 5th Multidisciplinary Conference on Sinkholes and the Engineering and Environmental Impacts of Karst, Gatlinburg, TN.
- Siegel, T.C., Belgeri, J.J., and Terry, M.W. (1999) "Compaction Grouting Versus Cap Grouting for Sinkhole Remediation in East Tennessee," *Proceedings*, 7th Multidisciplinary Conference on Sinkholes and the Engineering and Environmental Impacts of Karst, Hershey, PA.
- Sowers, G. F. (1996). *Building on sinkholes: design and construction of foundations in karst terrain*, ASCE Special Geotechnical Publication No. 14, 115-132.
- White, D.J., Suleiman, M.T., Phan, H.T., and Bigelow, J. (2002) "Shear Strength Envelopes for Aggregate used in Geopier® Foundation Construction." *Final Report*. Iowa State University.
- Wissmann, K. J. and Fox, N.S. (2000). "Design and analysis of short aggregate piers used to reinforce soils for foundation support." *Proceedings, Geotechnical Colloquium*. Technical University Darmstadt, Darmstadt, Germany.